

CHANGING HOOK HEIGHTS

36" to 54" Jib Height Adjustment Procedure:



CAUTION:

The following is the recommended procedure for changing hook heights on the adjustable jib from 36" to 54" heights. Failure to follow and adhere to this procedure may result in possible property damage and/or personal injury.



WARNING:

Make sure work area is clear of people and obstacles prior to changing the hook height on the adjustable jib.

1. With the telescopic arm in the transport position (as shown); remove the hitch pin from the lock pin. Then pull the lock pin loose from the jib arm.

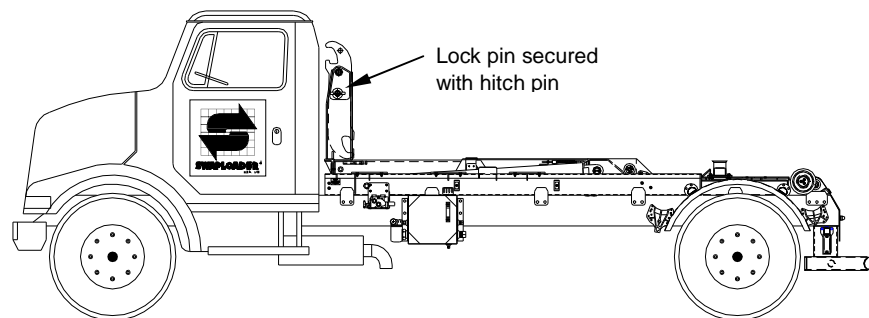

2. Retract the jib (right control lever backward). See Fig. A (Pg. 3-1).

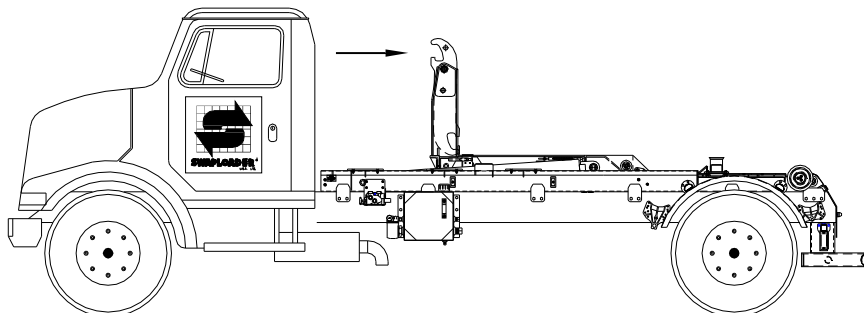

Changing Hook Height from 36" to 54" Continued:

3. Tilt the telescopic arm rearward (left control lever backward). See Fig. A (Pg. 3-1).

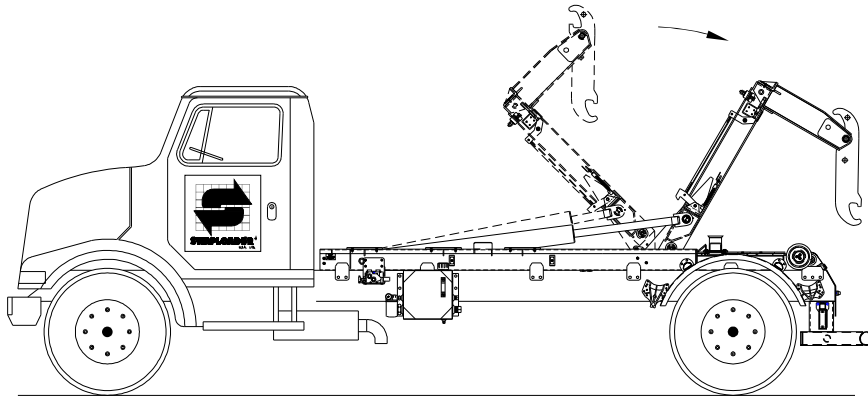

4. Continue to tilt telescopic arm rearward until the dump cylinders are fully extended. Replace lock pin and secure with hitch pin.

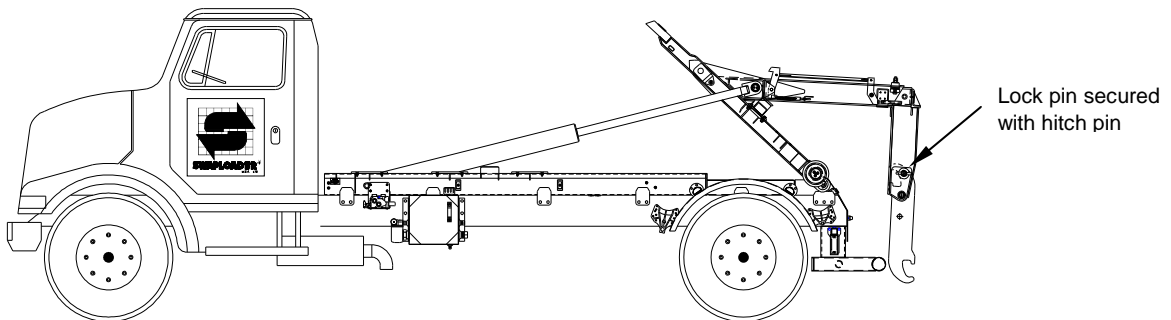

WARNING:

Do not remove lock pin on the adjustable jib while jib is in the 36" hook position and the telescopic arm is tilted rearward (as shown). Possible property damage and/or personal injury may result.

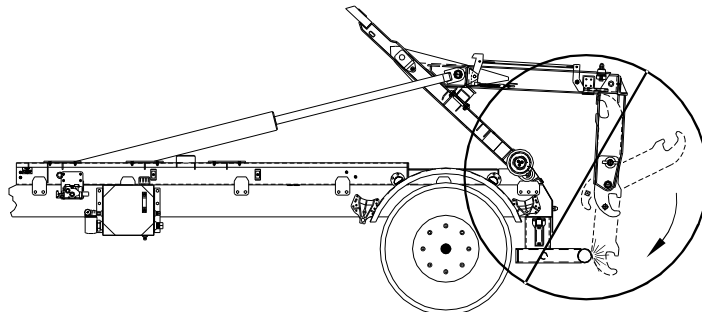

CHANGING HOOK HEIGHTS

54" to 36" Jib Height Adjustment Procedure:



CAUTION:

The following is the recommended procedure for changing hook heights on the adjustable jib from 54" to 36" heights. Failure to follow and adhere to this procedure may result in possible property damage and/or personal injury.



WARNING:

Make sure work area is clear of people and obstacles prior to changing the hook height on the adjustable

1. With the telescopic arm in full load/unload position (as shown); remove the hitch pin from the lock pin. Then pull the lock pin loose from the jib arm.

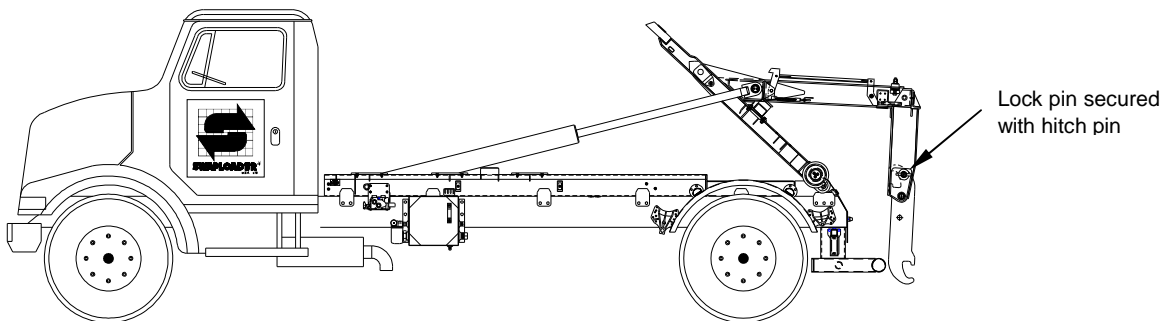

2. Tilt the telescopic arm toward the cab (left control lever forward). See Fig. A (Pg. 3-1).

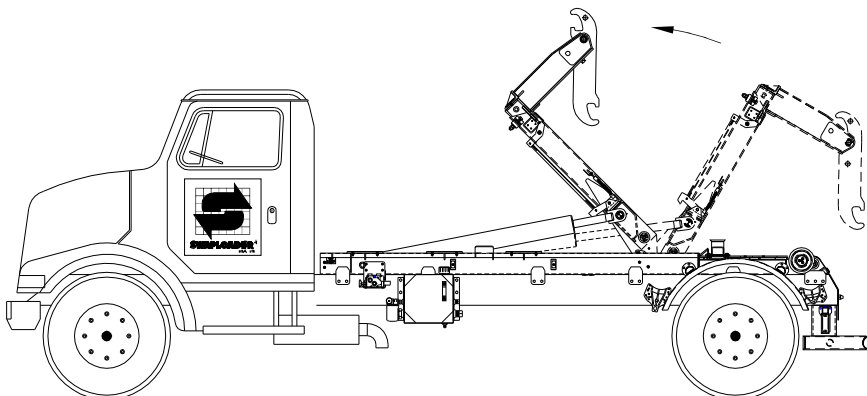

Changing Hook Height from 54" to 36" Continued:

3. Extend the jib toward the cab (right control lever forward). See Fig. A (Pg. 3-1).

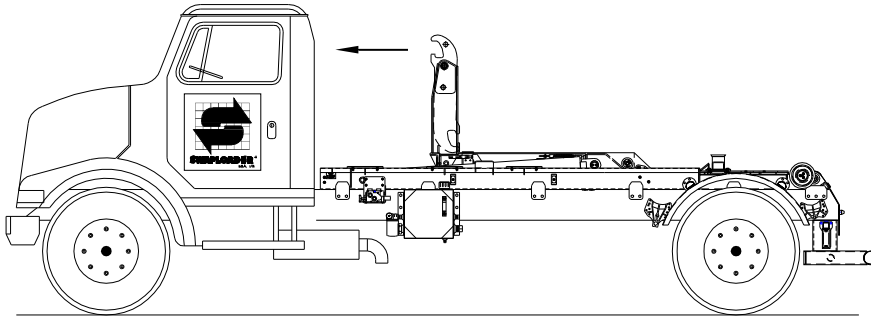

4. With the telescopic jib fully extended in the transport position (as shown); replace the lock pin and secure with hitch pin.

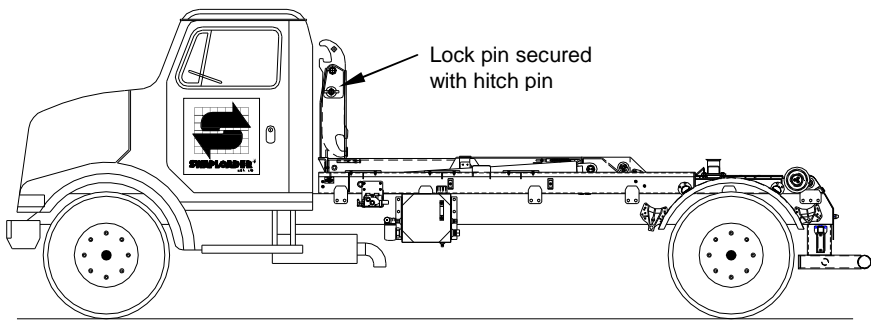

WARNING:

Do not remove lock pin on the adjustable jib while jib is up in the 54" hook position and telescopic arm in transport position (as shown). Possible property damage and/or personal injury may result.

